

## **ANNEX IV**

### **To the Notification**

*(Stipulations in exemption of Section 284 and 311 of M.S. Act)*

## **Construction Rules**

**Requirements for Type III and Type IV river-sea vessels under this Notification  
w.r.t.**

***Structure and Strength, Freeboard and Stability, Machinery, Bilge Systems,  
Electrical Installations and Structural Fire Protection***

---

## **Chapter 1            Structure and Strength of the Ship**

### **1.        General**

Ships shall be designed and maintained in compliance with the structural, mechanical and electrical requirements of a classification society for the intended operation. Ships shall be classed with a Classification Society authorised by the Government of India for the purposes of undertaking the operations envisaged under this Notification.

The Vessels shall be constructed in accordance to good shipbuilding practice. The hull of the vessel shall be sufficiently strong to withstand all stresses, to which it is subjected to in the normal operating conditions.

### **2.        Scope**

This Chapter shall apply to all welded single hull, steel ships of normal form and proportions and speed, and built in accordance to the Scantling requirements as specified by an authorised classification society for the intended operation.

Proposals to use alternative materials such as aluminium, or wood for some parts of the river-sea vessels shall receive special consideration. Alternate arrangements of scantlings, equipment may be considered, provided the equivalency of such arrangements can be substantiated by direct calculations. The calculation procedure and the assumptions made are to be submitted to the Recognised Organisation for approval.

### **3.        Applicability**

This chapter shall apply to river-sea vessels with length below 150 m in length and GT less than 3000.

#### **4. Stability**

The intact and damage stability requirements in compliance with Chapter 2 are to be demonstrated, prior to issuance of Indian River-Sea Vessel Safety Certificate

#### **5. Steel**

The ordinary hull structural steel is a hull structural steel with minimum yield strength of 235 N/mm<sup>2</sup> and a tensile strength in the range of 400-490 N/mm<sup>2</sup>.

Steels having a yield stress of 265 [N/mm<sup>2</sup>] and higher are regarded as higher tensile steels. Where higher tensile steel is used, the hull girder section modulus and the local scantlings may be reduced as approved by the RO.

#### **6. Principles for scantlings and structural details**

.1 The normal frame spacing between aft peak and 0.2L from F.P. may be taken as:  
450 + 2L [mm] for transverse framing

550 + 2L [mm] for longitudinal framing. However, it is generally not to exceed 1000 [mm].

.2 Any tapering of thickness of plating contributing to the longitudinal strength is to be based upon linear variation of stress allowed at specified regions.

For stiffeners, the span 'l' [m] is to be taken as the length of the stiffener between the two supporting members less the depth of stiffener on crossing panel if any.

For curved stiffeners, 'l' may be based on the chord length. For girders, the span 'S' [m] is to be taken as the length of the girder between the two supporting members, less the web height of in-plane girder if any

The area of the attached plating, to be used in the calculation of sectional properties of the stiffeners and girders, is to be taken as the cross-sectional area within the effective width of the attached plating.

The effective width of plating attached to a stiffener may be taken as the mean of spacing on either side of the stiffener.

The effective cross sectional area of the attached plating is not to be less than that of the faceplate.

- .3 Where openings are cut in the girder web, they are to be away from the girder ends and scallops for stiffeners; with their centre located as near to the neutral axis of the girder as practicable. Openings of depth exceeding 25% of the girder depth or 300 [mm] and, of length exceeding the depth of the girder or 60% of the secondary stiffener spacing, are to be reinforced all around at the edge; or alternatively by providing horizontal and vertical stiffeners.
- .4 Girders are to be provided with adequate lateral stability by tripping brackets fitted generally at every alternate stiffener in case of asymmetrical section or at every fourth stiffener
- .5 In case of symmetrical section; Tripping brackets are also to be fitted at the toes of end brackets and in way of concentrated loads such as heels of pillars or cross ties.
- .6 Where the width of faceplate on one side of the web exceeds 15 times the thickness the tripping brackets are to be connected to the faceplate.
- .7 The tripping brackets are to be adequately dimensioned at base and are to have a smooth transition to the adjoining stiffeners. The free edge of the tripping bracket is to be stiffened if its length exceeds 60 times thickness, additional stiffeners are to be fitted parallel to the free edge to ensure that the arm length of an un stiffened triangular end panel does not exceed 100 times the thickness.
- .8 The end attachments and supporting structure of the girders are to provide adequate resistance against rotation and displacement of the joint and effective distribution of the load from the member. Supporting members to which, the girders are being connected, may require additional strengthening to provide adequate stiffness to resist rotation of the joint. Where the end attachment provides only a low degree of restraint against rotation, the girder is generally to be extended beyond the point of support by at least two frame spaces before being gradually tapered.
- .9 Connections between girders forming a ring system are to be such as to minimize stress concentrations at the junctions. Integral brackets are generally to be radiused or well rounded at the toes.

.10 Where the faceplate of the girder is not continuous over the bracket, the free edge of the bracket is to be stiffened and the faceplate of the girder is to be extended well beyond the toe of the bracket.

.11 Scantlings of hull members subjected to compressive stresses are to specially considered for buckling stresses

## **7. Longitudinal strength**

### **7.1 General**

a) Scantlings of hull members contributing to longitudinal strength are to comply with the requirements given in this Chapter.

b) For river-sea vessels with small block coefficient, high speed and large flare (in particular where  $L > 120$  [m] and speed  $V > 17$  knots), the section modulus in the fore body is to be specially considered based on the distribution of still water and vertical wave bending moments.

c) For river-sea vessels with narrow beams the combined effects of vertical and horizontal bending of hull girder may have to be specially considered.

d) For river-sea vessels with large deck openings the combined effects of hull girder bending and torsion related possible local bending and shear stresses would have to be considered. Calculations and plans substantiating that the above are within acceptable limits are to be submitted to RO for approval.

e) Ships of unusual type, design or proportions ( $L/B \leq 5$ ,  $B/D \geq 2.5$ ), will be specially considered.

### **7.2 Section modulus**

The section modulus 'Z' at deck or at bottom shall not to be less than:

At any transverse section, the hull section modulus Z, about the transverse neutral axis based on the total bending moment (Hogging or Sagging) is not to be less than:

$$Z = \left( \frac{M_s + M_w}{\sigma_L} \right) \times 10^3 \text{ [cm}^3\text{]}$$

Where,

$\sigma_L$  = permissible bending stress

**= 175/K [N/MM2] WITHIN 0.4L AMIDRIVER-SEA VESSELS**

= 125/k [N/mm2] within 0.1L from A.P. and F.P.

Between the specified regions,  $\sigma_L$  is to be obtained by linear interpolation.

k = material factor

= 1.0 for steel of normal strength of  $\sigma_Y = 235$  N/mm2

= 0.78 for higher tensile strength steel of  $\sigma_Y = 315$  N/mm2

= 0.72 for higher tensile strength steel of  $\sigma_Y = 355$  N/mm2

$\sigma_Y$  = minimum yield stress of the steel under consideration.

$M_s$  = Maximum Still Water Bending Moment [kN-m] at the section under consideration, in all envisaged loading conditions.

$M_w$  = Wave bending moment [kN-m] at the section under consideration.

$M_w = K_{wm} \times M_{wo}$

Where  $K_{wm} = 1.0$  between 0.40L and 0.65L from A.P.

= 0.0 at A.P. and F.P.

Between the specified locations,  $K_{wm}$  is to be obtained by linear interpolation.

The Wave Bending Moment  $M_{wo}$ , at amidriver-sea vessels is to be taken as

$M_{wo} = (-) 0.11 C_w L^2 B (Cb + 0.7) 0.75$  [kN-m] – for sagging condition

= (+)  $0.19 C_w L^2 B Cb 0.75$  [kN-m] – for hogging condition

$C_w = 0.0856L$  for  $L \leq 90$  [m]

=  $10.75 - [(300-L)/100]^{3/2}$  for  $90 < L \leq 150$  [m]

### **7.3 Minimum Hull Section Modulus**

At Midship, the hull section modulus Z about the transverse neutral axis is also not to be less than:

$$Z = C_1 L^2 B (C_b + 0.7) 0.875 \text{ [cm}^3\text{]}$$

$$\text{Where, } C_1 = (4 + 0.0412 L)$$

Scantlings of all continuous longitudinal members of hull girder based on the section modulus requirement as above are generally to be maintained within 0.4L amidriver-sea vessels. In the region outside 0.4L amidriver-sea vessels, the scantlings are to be gradually tapered to the local requirements at ends.

## 7.4 Moment of inertia requirement

The moment of inertia in of the hull section about the transverse neutral axis, at midriver-sea vessel, is not to be less than:

$$I_n = 3 C_1 L^3 B (C_b + 0.7) 0.875 \text{ [cm}^4\text{]}.$$

## 7.5 Shear Strength

The shear stress ' $\tau$ ' in river-sea vessel's sides and longitudinal bulkheads based on the total shear force ( $Q_s + Q_w$ ) is not to exceed  $110/k$  [N/mm<sup>2</sup>].

The Notification for Indian river-sea vessels vertical wave shear force  $Q_w$  at any section along the length of the river-sea vessel is to be taken as:

$$Q_w = 0.3 K_{wq} C_w L B (C_b + 0.7) 0.75 \text{ [kN]}$$

Where, the distribution of  $K_{wq}$  for +ve and -ve shear forces, is to be obtained as per Table below. Between the specified locations  $K_{wq}$  is to be obtained by linear interpolation.

Table		
Location from A.P.	Positive Shear Force $K_{wq}$ (+)	Negative Shear Force $K_{wq}$ (-)
A.P.	0.0	0.0
0.2L to 0.3L	$\frac{1.589 C_b}{(C_b + 0.7)}$	-0.92
0.4L to 0.6L	0.70	-0.70

0.7L 0.85L	to	1.0	$\frac{-1.727 C_b}{(C_b + 0.7)}$
F.P.		0.0	0.0

## 7.6 Still water Bending Moment and Still water shear Force

Still water bending moments,  $M_s$  [kN-m], and still water shear forces,  $Q_s$  [kN], are to be calculated at each section along the river-sea vessel length for loading conditions as specified below.

For these calculations, downward loads are assumed to be taken as positive values, and are to be integrated in the forward direction from the aft end of L.

## 7.7 Loading Conditions to be considered for the Stability data.

- Homogeneous loading conditions at maximum draught
- Ballast conditions
- Special loading conditions e.g. container or light load conditions at less than maximum draught, heavy cargo, empty holds or non-homogeneous cargo conditions, deck cargo conditions etc., where applicable
- Docking condition afloat
- Loading and unloading transitory conditions, where applicable

## 7.8 Openings in longitudinal strength members

The keel plate is normally not to have any openings.

In the bilge plate, within 0.6L amidriver-sea vessels, openings are to be avoided as far as practicable. Any necessary openings in the bilge plate are to be kept well clear of the bilge keel.

Openings in the strength deck within 0.6L amidriver-sea vessels (within the cargo hold region for river-sea vessels with large hatch openings) are as far as practicable to be located inside the line of large hatch openings. Necessary openings outside this line are to be kept well clear of the river-sea vessel's side and hatch corners.

Openings in lower decks are to be kept well clear of the main hatch corners and other areas of high stresses.

Openings in the side shell, longitudinal bulkheads and longitudinal girders are not to be located within twice the opening breadth below the strength deck.

Small openings are generally to be kept well clear of other openings in the longitudinal strength members. The transverse distance between any two adjacent non-reinforced openings is not to be less than four times the breadth of the larger opening.

Openings exceeding 2.5 m in length or 1.2 [m] in breadth and scallops, where scallop welding is applied, are to be deducted from the sectional areas used in the section modulus calculation.

All openings are to be adequately framed; attention is to be paid to structural continuity, and abrupt changes of shape, section or plate thickness are to be avoided. Arrangements in way of corners and openings are to be such as to minimize the creation of stress concentrations.

## **8 Bottom structure**

### **8.1 General**

- a) Except as specified in (e), river-sea vessels for which this Notification for Indian river-sea vessels apply shall be fitted with a double bottom extending from the collision bulkhead to the after peak bulkhead as far as this is practical and compatible with the design and proper working of the river-sea vessel.
- b) Where a double bottom is required to be fitted, the inner bottom is to be continued to the river-sea vessels side in such a manner as to protect the bottom to the turn of the bilge.
- c) Small wells constructed in the double bottom, in connection with the drainage arrangement of holds, are not to extend in depth more than necessary. A well extending to the outer bottom may be permitted at the after end of the shaft tunnel of the river-sea vessel. Other wells may be considered provided the arrangements give protection equivalent to that offered by a double bottom.
- d) A double bottom need not be fitted in way of watertight compartments used exclusively for the carriage of liquids, provided the safety of the river-sea vessel is not impaired in the event of bottom damage.
- e) A double bottom need not be fitted on the following river-sea vessels:
  - 1) Cargo river-sea vessels having less than 500 GT.

- f) The engine room of all river-sea vessels having  $L > 90$  [m] are to have a double bottom.
- g) For river-sea vessels of  $L > 90$  [m], single bottoms within the cargo region, where permitted, are normally to be longitudinally stiffened.
- h) For river-sea vessels of  $L > 90$  [m] and for river-sea vessels intended for carriage of heavy cargoes, double bottoms within the cargo region are normally to be longitudinally stiffened.
- i) The continuity of the bottom, bilge and inner bottom longitudinal is to be maintained within  $0.5L$  amidriver-sea vessels.
- j) The bilge keel and the ground bar, to which it is attached, are to be gradually tapered at ends and arranged to finish in way of suitable internal stiffening. Butt welds in the bilge keel and the ground bar are to be well clear of each other and those in the shell plating.
- k) Adequate access is to be provided to all parts of the double bottom. The vertical dimension of lightening holes is not to exceed 50 per cent of the girder height. The diameter of lightening holes in the bracket floors is not to exceed  $1/3$  of the breadth of the brackets. Lightening holes or manholes are normally not to be cut in floors or girders towards their ends and under large pillars or supporting structures. Manholes in inner bottom are to have reinforcement rings, and the manhole covers in the inner bottom plating in cargo holds are to be effectively protected. The edges of all holes are to be smooth.
- l) To ensure the free passage of air and water from all parts of the tanks to air pipes and suctions, air and drain holes are to be provided in all non-watertight members. The air holes are to be placed as near to the inner bottom as possible and their total area is to be greater than the area of the filling pipes.
- m) The drain holes are to be placed as near to the bottom as possible. The access opening to pipe tunnel is to be visible above the floor plates and is to be fitted with a rigid watertight closing device. A notice board stating that the access opening to the pipe tunnel is to be kept closed is to be fitted near the opening. The opening is to be regarded as an opening in watertight bulkhead.

## **8.2 Keel plate**

The width of the plate keel is not to be less than  $(800+5L)$  [mm], nor greater than 1800 [mm]. The thickness is to be 2 [mm] greater than that required for the adjacent bottom plating.

## **8.3 Single bottom**

### **8.3.1 Transverse Framing.**

- .1 Floors are to be fitted at every frame. On all river-sea vessels one centre girder is to be fitted and in addition side girders are to be fitted such that the spacing of girders does not exceed 2.5 [m]. The girders are to extend as far forward and aft as practicable and where they are cut at transverse bulkheads the longitudinal strength is to be maintained. Where the bottom structure changes into a double bottom structure, the bottom girders are to extend at least 3 frame spaces into double bottom structures.
- .2 In the engine room, the thickness of floors webs and the faceplate area are to be increased by 1 [mm] and 50 per cent respectively. The floors are not to be flanged.
- .3 If the height of floors is reduced in way of crankcase, the faceplate area is to be suitably increased; however the reduced height is normally not to be less than 2/3 of floor depth at centre line.
- .4 In the after peak of single screw river-sea vessels, the height of the floors is to be increased such that their upper edge is well above the stern tube.

### **8.3.2 Longitudinal framing**

- .1 The spacing of bottom transverses is normally not to exceed the greater of  $0.02L$  [m] or 3.6 [m]. The bottom transverses are to be supported by primary girders or longitudinal bulkheads. Where the design does not incorporate a centreline bulkhead, at least a docking girder is to be provided. The scantlings of a complex girder system are to be based on a direct stress analysis, to the satisfaction of the administration.
- .2 The girders are to be satisfactorily stiffened against buckling. Tripping brackets are to be provided as required.

## 8.4 Double Bottom

### 8.4.1 General

- .1 Where double bottom spaces are used as tanks, the centre girder is to be watertight unless watertight side girders divide the double bottom or the tanks are narrow.
- .2 Longitudinal stiffeners are to have end connections; other stiffeners may be sniped at ends provided the section modulus is increased by 25 per cent.
- .3 The longitudinal girders are to be satisfactorily stiffened against buckling.

### 8.4.2 Transverse framing

- .1 The side girders are normally to be fitted at a spacing not exceeding 4.0 [m] and are to be extended as far forward and aft as practicable. The girders are to be stiffened at every bracket floor by a vertical stiffener of depth same as that of reverse frame and thickness that of the girder.
- .2 Plate floors are to be fitted under bulkheads, pillars, thrust seating, boiler bearers and in way of change of depth of double bottom. In engine room, plate floors are to be fitted at every frame. Elsewhere the spacing of plate floors is not to exceed that given by Table 8.2 below.

Draught T [m]	Under deep tanks (See Note 1)	Clear of deep tanks (maximum 3.0 [m])
$T \leq 2$	Every 4th frame	Every 6th frame
$2 < T \leq 5.4$	Every 3rd frame	Every 5th frame
$5.4 < T \leq 8.1$	Every 3rd frame	Every 4th frame
$T > 8.1$	Every 2nd frame	Every 3rd frame
Note 1 : Under tanks with height greater than 0.7 times the distance between inner bottom and main deck		

- .3 The bottom frames and reverse frames are to be attached to the centre girder and margin plate by means of brackets of same thickness as that of the plate floors. The

breadth of the brackets is not to be less than 0.75 times the depth of the centre girder and the brackets are to be flanged 75 [mm] at their free edges.

- .4 Where vertical struts are fitted, the section modulus of the bottom and inner bottom transverses may be reduced by 35 per cent.

### **8.4.3 Longitudinal framing**

- .1 The side girders are normally to be fitted at a spacing not exceeding 5.0 [m] and are to be extended as far forward and aft as practicable.
- .2 The plate floors are to be fitted under bulkheads, pillars, and other areas where concentrated loads are contemplated. In engine room, plate floors are to be fitted at every second side frames. Additionally, under the main engine seating, floors extending to the first side girder outside the engine seating are to be fitted at intermediate frames. Under deep tanks with height greater than 0.7 times the distance between inner bottom and main deck, the spacing of floors is normally not to exceed 2.5 [m]. Elsewhere, the spacing is normally not to exceed 3.6 [m].
- .3 The plate floors are to be stiffened at every longitudinal by a vertical stiffener of depth same as that of the inner bottom longitudinal and thickness as that of the floor. Between plate floors, transverse brackets are to be fitted at every frame at the margin plate and at a spacing not exceeding 1.25 [m] on either side of the centre girder. The thickness of brackets is to be same as that of the plate floors. The brackets are to extend up to the adjacent longitudinal and are to be flanged 75 [mm] at their free edges.
- .4 Where vertical struts are fitted similar to transversely framed structure, the section modulus of the bottom and inner bottom longitudinal may be reduced by 35 per cent.

### **8.4.4 Additional Strengthening against Slamming**

- .1 Where the minimum design ballast draught at F.P. is less than  $0.04L$  [m], the bottom forward is to be additionally strengthened; the details are required to be specially considered.

## **9 Side structure**

## 9.1 Structural Arrangement and Details

- .1 The river-sea vessel's side shell may be stiffened longitudinally or vertically.
- .2 Where the side shell is stiffened longitudinally, the continuity of the side longitudinal within a distance of  $0.15D$  from bottom or from strength deck is to be maintained within  $0.5L$  amidriver-sea vessels. The web frames are to be fitted in line with the bottom transverses or plate floors.
- .3 The position, shape and reinforcement of sea inlets or other openings in side shell are to be approved.
- .4 In the case of superstructures exceeding  $0.15L$  in length and ending within  $0.5L$  amidriver-sea vessels, the side plating of the superstructures is to be increased by 25 per cent in way of the break.
- .5 The thickness of the shell plating is to be increased locally by 50 per cent in way of stern frame, propeller brackets and rudder horn. In way of anchor pockets, hawse pipes etc, the side shell is to be additionally reinforced.

## 9.2 Sheer strake

- .1 The thickness of sheer strake is to be increased by 30 per cent on each side of a superstructure end bulkhead located within  $0.5L$  amidriver-sea vessels if the superstructure deck is a partial strength deck.
- .2 Where a rounded sheer strake is adopted the radius in general, is not to be less than 15 times the plate thickness.
- .3 Bulwarks are generally not to be welded to the top of the sheer strake within  $0.6L$  amidriver-sea vessels.
- .4 Where the sheer strake extends above the deck stringer plate, the top edge of the sheer strake is to be kept free from notches and isolated welded fittings, and is to be ground smooth with rounded edges. Drainage openings with smooth transition in the longitudinal direction may be allowed on special consideration.

- .5 The welding of deck fittings to rounded sheer strake within 0.6L amidriver-sea vessels is not permitted, unless approved in each case.
- .6 The breadth of the sheer strake is not to be less than  $(800+5L)$  [mm], however for river-sea vessels of  $L < 90$  [m], it need not exceed  $200 D$  [mm].
- .7 Where the thickness of the strength deck plating is greater than that required for side plating, the sheer strake thickness is not to be less than the mean of the two values.
- .8 Side shell vertical frames are to be adequately bracketed. Where the free edge of the bracket exceeds 40 times the bracket thickness, the brackets are to be flanged. The flange width is to be at least  $1/15$  of the length of the free edge.
- .9 Brackets at ends of the frames may be omitted provided the frame is carried through the supporting members and the section modulus required as indicated above is increased by 75 per cent.
- .10 The lower end of the tween deck and superstructure frames is to be connected to the bracket or frame below or else it is to be bracketed above the deck. The upper end is to be bracketed to the deck beam or longitudinal.

### **9.3 Tripping brackets**

- .1 Where the span of frames exceeds 5 [m] and/or the flange width is less than  $1/20$  of the span 'l', tripping brackets are to be fitted at the middle of the span.

### **9.4 Girders**

- .1 Web frames are to be fitted in way of hatch end beams and deck transverses.
- .2 In the engine and boiler room, web frames are to be fitted at the forward and aft end of the engine and every 5th frame in general. In addition, where the engine room is situated aft and the span of the frames up to the lowest deck exceeds 6.5 [m], a side stringer is to be provided. The depth of the webs and stringers are not to be less than 2.5 times the depth of the ordinary frames.
- .3 Adequate deep beams are to be provided in line with the web frames.

- .4 In peak spaces, side stringers supporting vertical peak frames are normally to be fitted at every 2.6 [m]. The stringers are to be supported by web frames.
- .5 Alternatively in fore peak spaces unflanged stringers supported by panting beams at alternate frames may be provided.
- .6 The panting beams are to comply with buckling strength requirement, and to be bracketed to the frames. Intermediate frames are to be bracketed to the stringers.
- .7 The girders are to be satisfactorily stiffened against buckling.

## 10 Deck structure

### 10.1 General

.1 The continuity of the deck longitudinal is to be maintained within 0.5 L amidriver-sea vessels. However, for vessels having length less than 90 m, arrangements where longitudinal abutting transverse structure would be specially considered.

.2 The deck within the line of hatchway openings is preferably to be stiffened transversely or alternatively the arrangements are to provide adequate transverse buckling strength. Where the deck outside the line of hatchway openings is framed longitudinally, the transverse beams or buckling stiffeners between the hatchways are to extend at least up to the second longitudinal from the hatch side or equivalent.

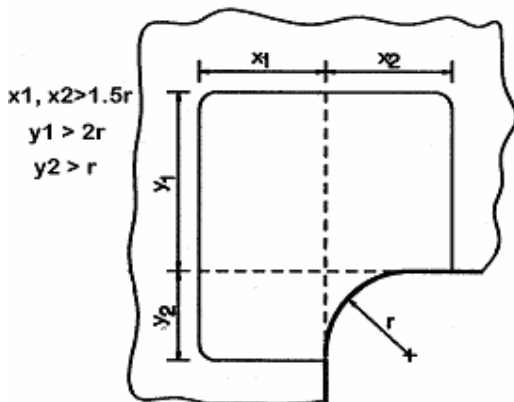

Fig.2.1.6 : Extent of insert plate

The radius  $r$  shall be calculated as indicated below

$$r = 0.03 (1.5 + l/b) (B-b).$$

Where  $l$  = the longitudinal distance between two adjacent hatchways and  $b$  = breadth of the hatchway.

.3 In river-sea vessels with large hatch openings, the effective cross-sectional area of the deck between the hatchways is to be sufficient to withstand the transverse load acting on the river-sea vessel's sides. Bending and shear stresses arising as a result of loading on the transverse bulkhead supported by the deck area and also as a result of displacements caused by torsion of the hull girder are to be considered and the necessary reinforcements are to be provided.

.4 The following items may be included in the effective cross-sectional area of the decks;

- a) Deck plating
- b) Transverse beams and deck transverses
- c) Hatch end beams (upon special consideration)
- d) Cross section of stool at top of transverse bulkhead
- e) Cross-section of transverse bulkhead (if plane or horizontally corrugated) down to base of top wing tank or to  $0.15 D$  from deck.

.5 Hatchway corners are to be of streamlined, elliptical or circular shape. Where shapes other than the streamlined shape or equivalent are adopted, insert plates are to be fitted at the hatch corners in strength deck. The insert plates are to be 25 per cent thicker than the deck plating outside the line of hatchways and are to extend as shown in figure above. The butts of insert plates are to be well clear of those in coaming.

.6 The thickness of the strength deck plating outside the line of hatchway openings is to be adequate to give the necessary hull section modulus and moment of inertia.

.7 Where approved deck coverings are provided, the deck thickness may be reduced by 10 per cent without being less than 5.0 [mm].

- .8 The strength deck plating outside the line of hatchways is also to comply with the requirements of buckling strength.
- .9 Deck girders and transverses are to be arranged in line with vertical members of scantlings sufficient to provide adequate support.
- .10 The scantlings of a complex girder system are to be based on a direct stress analysis; the calculations and assumptions are to be submitted to the directorate for consideration.
- .11 The scantlings of cantilever beams and supporting frame will be specially considered.

## **10.2 Pillars**

- .1 The scantlings of the pillars are to be designed to meet the buckling requirements. Axial load, if any, from pillars above is to be added to the load from deck girders.
- .2 Pillars are to be fitted in the same vertical line wherever possible, and arrangements are to be made to effectively distribute the load at the heads and heels. Where pillars support eccentric loads, they are to be strengthened for the additional bending moments imposed upon them. Doubling or insert plates are generally to be fitted at the head and heel of hollow pillars.
- .3 The pillars are to have a bearing fit and are to be attached to the head and heel plates by continuous welding.
- .4 Where the heels of hold pillars are not directly above the intersection of plate floors and girders; partial floors and intercostal girders are to be fitted as necessary to support the pillars. Lightening holes or manholes are not to be cut in the floors and girders below the heels of pillars.
- .5 Inside tanks, hollow pillars are not to be used and strengthening at the heads and heels of pillars is not to be obtained by means of doubling plates.

## **10.3 Decks for Wheel Loading**

- .1 Where it is proposed either to stow wheeled vehicles on the deck or to use wheeled vehicles for cargo handling, the deck strengthening is to be specially considered. The details are to be submitted to the directorate, substantiating with calculations and assumptions

## **10.4 Decks with container loading**

- .1 Where containers are stowed, the deck structure in way of containers shoes are to be specially considered, details with substantiating calculations and assumptions is to be submitted to RO for approval prior to commencement of construction of the vessel.

## **11 Bulkheads**

Where applicable, the number and disposition of bulkheads are to be arranged to meet the requirements for subdivision, floodability and damage stability in accordance with the requirements specified in other parts of this Notification for Indian river-sea vessels.

### **11.1 Number of bulkheads**

The following transverse watertight bulkheads are to be fitted in all river-sea vessels:

A collision bulkhead;

An after peak bulkhead;

A bulkhead at each end of the machinery space.

For river-sea vessels without longitudinal bulkheads in the cargo region, additional transverse watertight bulkheads are to be fitted so that the total number of bulkheads is not less than that given in Table below

<b>Table: Total no. of bulkheads</b>
--------------------------------------

Ship length [m]	Engine Room Location	
	Aft*	Elsewhere
$L \leq 65$	3	4
$65 < L \leq 85$	4	4
$85 < L \leq 105$	5	5
$105 < L \leq 115$	5	6
$115 < L \leq 125$	6	6
$125 < L \leq 145$	6	7
$145 < L \leq 150$	7	8
* With aft peak bulkhead forming after boundary of machinery space		

The ordinary transverse watertight bulkheads in the holds shall be spaced at reasonably uniform intervals. Where non-uniform spacing is unavoidable and the length of a hold is unusually large, the transverse strength of the river-sea vessel is to be maintained by providing additional web frames, increased framing etc.

Proposals to dispense with one or more of these bulkheads will be considered, subject to suitable structural compensation, in case they interfere with the requirements of a special trade.

## 11.2 Position of collision bulkhead

The distance  $X_c$  from the forward perpendicular to the collision bulkhead is to be between 0.05 LL and 0.08 LL

LL = the load line length of the vessel [m], as per International Load Line Convention.

Consideration will however be given to proposals for the collision bulkhead positioned aft of the limits given above, provided that the application is accompanied by calculations showing that with the river-sea vessel fully loaded to summer draught on even keel, flooding of space forward of the collision bulkhead will not result in any part of the freeboard deck becoming submerged, nor result in any unacceptable loss of stability.

Any recesses or steps in collision bulkheads are to fall within the limits of bulkhead positions given above. Where the bulkhead is extended above the freeboard deck, the extension need

only be to weather tight standards. If a step occurs at that deck, the deck also need be to only weather tight standards in way of the step unless the step forms the crown of a tank.

### **11.3 After peak bulkhead and shaft tunnel**

All river-sea vessels are to have an after peak bulkhead generally enclosing the stern tube and rudder trunk in a watertight compartment. In twin-screw river-sea vessels where the bossing ends forward of the after peak bulkhead, the stern tubes are to be enclosed in suitable watertight spaces inside or aft of the shaft tunnels.

In river-sea vessels with engines situated amidriver-sea vessels, a watertight shaft tunnel is to be arranged. Openings in the forward end of shaft tunnels are to be fitted with watertight sliding doors capable of being operated from a position above the load water line.

### **11.4 Height of bulkheads**

The watertight bulkheads are in general to extend to the freeboard deck. The after peak bulkhead however, may terminate at the first deck above the load waterline, provided that this deck is made watertight to the stern or to a watertight transom floor.

The collision bulkhead is normally to extend to the uppermost continuous deck or, in the case of river-sea vessels with combined bridge and forecastle or a long superstructure that includes a forecastle, to the superstructure deck. However, if a river-sea vessel is fitted with more than one complete superstructure deck, the collision bulkhead may be terminated at the deck next above the freeboard deck. Where the collision bulkhead extends above the freeboard deck, the extension need only be to weather tight standard.

### **11.5 Openings in watertight bulkheads and closing appliances**

Openings may be accepted in watertight bulkheads except in that part of collision bulkhead, which is situated below the freeboard deck. The number of openings in watertight subdivisions is to be kept to a minimum compatible with the design and proper working of the river-sea vessel. Where penetrations of watertight bulkheads are necessary for access, piping, ventilation, electrical cables, etc., arrangements are to be made to maintain the watertight integrity. Relaxation in the water tightness of openings above the freeboard deck

may be considered provided it is demonstrated that any progressive flooding can be easily controlled and that the safety of the river-sea vessel is not impaired.

Doors are to be subjected to a functional test and are to be tested for tightness by hose or soap.

Openings in the collision bulkhead above the freeboard deck are to have weather tight doors or an equivalent arrangement.

Doors, manholes, permanent access openings or ventilation ducts are not to be cut in the collision bulkhead below the freeboard deck.

Where watertight bulkhead stiffeners are cut in way of watertight doors in the lower part of the bulkhead, the opening is to be suitably framed and reinforced. Where stiffeners are not cut but the spacing between the stiffeners is increased on account of watertight doors, the stiffeners at the sides of the doorways are to be increased in depth and strength so that the efficiency is at least equal to that of the un-pierced bulkhead, without taking the stiffeners of the door-frame into consideration.

## **11.6 Doors in watertight bulkheads for river-sea vessels where subdivision / damage stability requirements are applicable**

These requirements apply to doors located in way of the internal watertight subdivision boundaries necessary to ensure compliance with the relevant subdivision and damage stability regulations.

These requirements do not apply to doors located in external boundaries above equilibrium or intermediate water planes.

For the purpose of the requirements in this subsection the following definitions shall apply:

**Watertight:** Capable of preventing the passage of water in any direction under a design head. The design head for any part of a structure shall be determined by reference to its location relative to the bulkhead deck or freeboard deck, as applicable, or to the most unfavourable equilibrium / intermediate water plane, in accordance with the applicable subdivision and damage stability regulations, whichever is the greater. A watertight door is

thus one that will maintain the watertight integrity of the subdivision bulkhead in which it is located.

**Equilibrium Water plane:** The water plane in still water when, taking account of flooding due to an assumed damage, the weight and buoyancy forces acting on a vessel are in balance. This relates to the final condition when no further flooding takes place or after cross flooding is completed.

**Intermediate Water plane:** The water plane in still water, which represents the instantaneous floating position of a vessel at some intermediate stage between commencement and completion of flooding when, taking account of the assumed instantaneous state of flooding, the weight and buoyancy forces acting on a vessel are in balance.

**Sliding Door or Rolling Door:** A door having a horizontal or vertical motion generally parallel to the plane of the door.

**Hinged Door:** A door having a pivoting motion about one vertical or horizontal edge.

Doors are to be of approved design and are to be of strength equivalent to that of the subdivision bulkheads in which they are fitted. Doors are to be fitted in accordance with all requirements regarding their operation mode, location and outfitting, i.e. provision of controls, means of indication etc. All doors, except those, which are to be permanently closed at sea, are to be capable of being opened and closed by hand, (and by power, where applicable) locally, from both sides of the doors, with the river-sea vessel listed to either side. The angle of list at which operation by hand is to be possible is 30 degrees.

## **11.7 Cofferdams**

Cofferdams are to be provided between the following spaces to separate them from each other:

Tanks for fuel oil or lubricating oil

Tanks for fresh water and feed water.

Tanks for lubricating oil are also to be separated by cofferdams from those carrying fuel oil. However, these cofferdams need not be fitted provided that the common boundaries have full penetration welds and the head of lubricating oil is not less than that in the adjacent fuel

oil tanks. In this case, a permanent notice is to be displayed near the lubricating oil tank that the oil level is not to be less than that in the adjacent fuel oil tank at any time.

In river-sea vessels of 400 GT and above, compartments forward of the collision bulkhead are not to be arranged for carriage of oil and other inflammable liquids.

Oil fuel in the deep tanks is to have a flash point of 60°C and above in closed cup test. Fuel Oil storage capacity of Type 3 and Type 4 vessels shall not exceed 600 m<sup>3</sup>.

If cargo is carried in a compartment adjacent to an oil fuel-settling tank, which may be heated, the compartment side of the bulkhead (or deck) is to be insulated, or equivalent arrangements to be provided.

The continuity of bulkhead longitudinal within a distance of 0.15D from the bottom or the strength deck is to be maintained, to the satisfaction of the administration.

Carlings, girders or floors are to be fitted below the corrugated bulkheads at their supports. These supporting members are to be aligned to the face plate strips of the corrugations.

## **11.8 Wash bulkheads**

A centerline wash bulkhead is to be fitted in peak spaces used as tanks, where the breadth of the tank exceeds 0.5B and also in deep tanks used for fuel oil extending from side to side.

The area of perforations is generally within 5% to 10% of the total area of bulkhead. The plating is to be suitably stiffened in way of the openings.

## **11.9 Supporting bulkheads**

Bulkheads or parts thereof supporting deck structure are also to be designed as pillars.

## **12 Super structure, deckhouses**

Where the summer freeboard is increased such that the resulting draught is not more than that corresponding to the minimum summer freeboard for the same river-sea vessel from an assumed freeboard deck located at a distance equal to or greater than the standard superstructure height below the actual freeboard deck;

The actual freeboard deck may be treated as the superstructure deck, while considering the requirements given in this chapter.

Where the freeboard is increased in accordance to above, the first tier above the uppermost continuous deck may be treated as the second tier. The lowest tier is normally the tier that is directly situated on the deck to which the depth 'D' is measured.

Long deckhouse is a deckhouse having more than 0.2L of its length within 0.4L amidriver-sea vessels.

## **12.1 Structural continuity**

Adequate transverse strength is to be provided to the deckhouses and superstructures by means of transverse bulkheads, girders and web frames.

The front and the after end bulkheads of the superstructures and deckhouses shall be effectively supported below by a transverse bulkhead or by a combination of partial bulkheads, girders and pillars. Similarly, the exposed sides and internal bulkheads of various tiers of erections are to be located, as far as practicable, above bulkheads or above deep girders below, or equivalent.

Adequate web frames are to be provided in way of large openings, boat davits and other points of high loading.

All openings cut on the sides are to be substantially framed and have well-rounded corners. Continuous coaming or girders are to be fitted below and above doors and similar openings. The size and number of openings on the sides are to be avoided or minimized at the ends of erections situated within 0.4L amidriver-sea vessels.

At the ends of superstructures, which have no set-in from the river-sea vessels' side, and at the ends of poop and bridge, the side plating is to extend beyond the ends of the superstructure, and is to be gradually reduced in height down to the sheer strake. The

transition shall be smooth and without any discontinuity. The extended plating is to be adequately stiffened, particularly at its upper edge.

Deck girders are to be fitted below the sides of long deckhouses and are to extend at least three frame spaces beyond the deckhouse ends. The depth of the girders is to be at least 100 [mm] greater than the depth of the beams and the girders are to be adequately stiffened at the lower edge.

The connection area between the corners of long deckhouses and deck plating shall be increased locally. Deck beams under the corners of deckhouses are not to be scalloped for a distance of 0.5 [m] on either side of the corners.

## **12.2 Navigation bridge visibility**

Chapter V Regulation 22 of SOLAS 1994, as amended shall be applicable to river-sea vessels having  $L_L$  greater than or equal to 45 [m].

## **12.3 Bulwark construction**

Bulwarks or guardrails are to be provided on the exposed parts of the freeboard and superstructure decks and also on the first tier of the deckhouse decks. The height of the bulwarks or guardrails measured above the sheathing, if any, is not to be less than 1.0 [m]. Consideration will be given to cases where this height would interfere with the normal operation of the river-sea vessel.

Bulwarks are to be stiffened at the upper edge by a strong rail section and supported by stays from the deck. The spacing of stays forward of 0.07L from F.P. is to be not more than 1.2 [m] on Type 'A', Type 'B-60' and Type 'B-100' river-sea vessels as defined in the ILLC, and not more than 1.8 [m] on other types. Elsewhere, the bulwark stays are to be not more than 1.8 [m] apart. Where bulwarks are cut in way of a gangway or other openings, stays of increased strength are to be fitted at the ends of the openings.

Bulwark stays are to be supported by, or are to be in line with, suitable under deck stiffening, which is to be connected by double continuous fillet welds in way of the bulwark stay connection.

Bulwarks are to be adequately strengthened in way of the eye plates for cargo gear, and in way of the mooring pipes the plating is to be increased in thickness and also adequately stiffened.

Bulwarks are generally not to be welded to the top of the sheer strake within 0.6L amidriver-sea vessels.

Bulwarks shall not be cut in way of the breaks of the superstructures, and are also to be arranged to ensure their freedom from main structural stresses. At the ends of the superstructures where the side plating is extended and tapered to align with the bulwark plating, the transition plating is to be suitably stiffened and supported. Where freeing ports or other openings are essential in this plate, they are to be suitably framed and kept well clear of the free edge.

The thickness of the bulwark plating is not to be less than that required for the superstructure side plating in the same location if the height of the bulwark is equal to or greater than 1.8 [m]. Where the height of the bulwark is 1.0 [m], the thickness need not exceed 6.0 [mm]. For intermediate bulwark heights the thickness may be obtained by interpolation.

When the bulwark is subjected to loads from any deck cargo, the scantlings will be specially considered.

## **12.4 Freeing arrangements**

Where bulwarks on the weather portion on freeboard or superstructure decks form wells, provision is to be made for rapidly freeing the decks of water.

## **12.5 Guardrails**

Fixed, removable or hinged stanchions shall be fitted about 1.5 [m] apart.

At least every third stanchion shall be supported by a bracket or stay.

Wire ropes may only be accepted in lieu of guardrails in special circumstances and then only in limited lengths.

Lengths of chain may be accepted in lieu of guardrails if they are fitted between two fixed stanchions and/or bulwarks.

The clear opening below the lowest course of the guardrails is not to exceed 230 [mm]. Where this course is not measured from the deck, but from the sheer strake or a waterway bar, which is not in the same vertical plane as the rails, the length of opening is the diagonal distance between the lowest of the rails and the top of the sheer strake or waterway bar. The other courses are not to be more than 380 [mm] apart. Where rounded gunwales are fitted the guardrail supports are to be placed on the flat of the deck, as close as possible to the beginning of the curvature of the gunwale.

Wires shall be made taut by means of turnbuckles.

Removable or hinged stanchions shall be capable of being locked in the upright position.

## **13 Anchoring and Mooring Equipment**

### **13.1 Introduction**

The vessels shall be provided with anchoring and mooring equipment, in accordance to the requirements specified by a recognized classification society, for the intended operation.

### **13.2 Design of the anchoring equipment**

The anchoring equipment required herewith is intended for temporary mooring of a vessel within a harbour or sheltered area when the vessel is awaiting berth, tide, etc.

The equipment is therefore not designed to hold a river-sea vessel off fully exposed coasts in rough weather or to stop a river-sea vessel, which is moving or drifting. In this condition the loads on the anchoring equipment increase to such a degree that its components may be damaged or lost owing to the high-energy forces generated, particularly in large river-sea vessels.

The anchoring equipment presently required herewith is designed to hold a river-sea vessel in good holding ground in conditions such as to avoid dragging of the anchor. In poor holding ground the holding power of the anchors will be significantly reduced.

The anchoring equipment required here under is based on an assumed current speed of 2.5 m/sec. wind speed of 25 m/sec and a scope of chain cable between 6 and 10, the scope being the ratio between lengths of chain paid out and water depth.

It is assumed that under normal circumstances a river-sea vessel will use only one bow anchor and chain cable at a time.

### **13.3 Documentation**

The arrangement of anchoring and mooring equipment and calculations are to be submitted for information.

The anchors are normally to be housed in hawse pipes and anchor pockets of adequate size, scantlings and suitable form to prevent movement of anchor and chain due to wave action.

The arrangements are to provide an easy lead of chain cable from windlass to the anchors. Upon release of the brake, the anchors are to immediately start falling by their own weight. Substantial chafing lips are to be provided at shell and deck. These are to have sufficiently large, radiused faces to minimise the probability of cable links being subjected to large bending stresses. Alternatively, roller fairleads of suitable design may be fitted.

Alternative arrangements for housing of anchors shall be specially considered.

The shell plating and framing in way of the hawse pipes are to be reinforced as necessary.

On river-sea vessels provided with a bulbous bow, and where it is not possible to obtain ample clearance between shell plating and anchors during anchor handling, adequate local reinforcements on bulbous bow are to be provided.

The chain locker is to have adequate capacity and depth to provide an easy direct lead for the cable into the chain pipes, when the cable is fully stowed. The chain pipes are to be of suitable size and provided with chafing lips. The port and starboard cables are to have separate spaces.

The chain lockers boundaries and chain pipes are to be watertight up to the weather deck. Bulkheads, which form common boundary of chain lockers, need not be watertight.

Provisions are to be made to minimize the ingress of water to the chain locker in bad weather. The chain pipes are to be provided with permanently attached closing appliances such as steel plates with cutouts for chain links or canvas hoods with lashing arrangements.

Provisions are to be made for securing the inboard ends of the chains to the structure. The strength of this attachment shall be between, 15 per cent to 30 per cent of the breaking strength of the chain cable. It is recommended that suitable arrangements be provided so that in an emergency the chain can be readily made to slip from an accessible position outside the chain locker.

The windlass and chain stoppers are to be efficiently bedded and secured to deck. The thickness of deck plating is to be increased in way of the windlass and chain stoppers and adequate stiffening underneath is to be provided.

## Chapter 2 Freeboard and Stability

### 1 Definitions:

*Subdivision load line:* Water line used to determine the sub division of the river-sea vessel.

*Deepest sub division load line:* Sub division load line corresponds to the summer draught to be assigned to the river-sea vessel.

*Sub division length of the river-sea vessel (L<sub>s</sub>)* is the greatest projected moulded length of that part of the river-sea vessel at or below deck or decks limiting the vertical extent of flooding with the river-sea vessel at deepest subdivision load line

### 2 Freeboard

The Load Line shall be assigned in accordance to Merchant Shipping (Load Line) Rules, 1979 as amended, except that:

**For Type III Vessels** Second Schedule Part II Rule 4 (2) (8) (Correction for hatch covers) shall not be applicable.

**For Type III** vessels shall have a minimum bow height, which shall not be less than the aggregate of the tabular freeboard and the standard sheer at the forward perpendicular applicable to the river-sea vessel, in lieu of complying with the requirements of Second Schedule Part II Rule 14 (2) of Merchant Shipping (Load Line) Rules.

**Type III** Vessels having length less than 90 m, carrying cargoes of such nature that it would not be adversely affected by contact with sea water, may not be fitted with hatch covers, provided the distance of the top of hatch coaming above the assigned waterline is not less than that required by Annexure IV to this Notification for Indian river-sea vessels. For type 3 vessels having length more than 90 m the minimum distance of the top of hatch coaming above the assigned waterline shall be 2.3 m.

Vessels not provided with hatch covers, shall carry only such cargoes, which are suitable and safe for carriage in open hatch vessels without impairing the safety of the vessel and the crew and without any adverse impact on the vessel, or cargo.

Where such vessels are not provided with hatch covers in accordance with paragraph above, they shall comply with, in hold flooded conditions, the stability criteria given below and have a minimum freeboard of 100mm from the trimmed waterline to deck at side at any location along the length of the vessel. For calculation of trim and stability in the flooded condition, flooding of cargo holds up to the top of coaming is to be considered. For the purpose of these calculations, appropriate combination(s) of cargo permeability & densities are to be taken as per the envisaged loading conditions included in the approved Loading Manual. As a minimum, the combinations given in the table below are to be taken into account, as applicable.

Cargo	Permeability	Density of cargo (t/m <sup>3</sup> )
Iron Ore	0.3	3.0
Coal	0.3	0.9
Sand	0.5	2.0

For the purpose of these calculations the permeability of void spaces above the cargo level are to be taken as 1.0 and the density of sea water as 1.025 t/m<sup>3</sup>

Where such Type III river-sea vessels are not provided with hatch covers the minimum height of the hatchway coaming above load water line shall be as follows:

These vessels where hatch covers are not fitted the minimum distance of top of hatch coaming above the assigned water line (h) shall be calculated by the following formula.

$$h = A \quad \text{For } \frac{X}{L} < 0.8$$

$$h = A + B\alpha^2 + C\alpha \quad \text{For } 0.8 \leq \frac{X}{L} \leq 1.0$$

Where

$$A = 1.2 + 0.0065L$$

$$B = \frac{3L}{1000}(L - 100)$$

$$C = \frac{L}{250}(90 - L)$$

$$\alpha = \frac{X}{L} - 0.8$$

L = Length of the vessel

X = Distance from AP to the section under consideration

~~**Type 4** Vessels shall be provided with Hatch covers in accordance to MS (Load Line) Rules 1979, as amended.~~

**Type IV** vessels having length  $L_s$  of 80 m and upwards shall also comply with the requirements of Part B-1, Chapter II-1 of SOLAS as amended.

### 3 Intact Stability

Subject to the provisions of paragraphs a) and b) vessels shall comply with the intact stability requirements for cargo river-sea vessels specified in the Rule on Intact Stability for All Types of Ships Covered by IMO Instruments, adopted by the International Maritime Organization by resolution A.749 (18) as amended.

- a) Existing river-sea vessels shall, as far as practical and reasonable in the opinion of the Administration, comply with the requirements of this section.
  
- b) For **Type III** vessels considering to the nature of operation during fair weather, the vessel shall, as a minimum, comply with the following criteria: -
  - 1) The Initial Metacentric Height (GM<sub>0</sub>) shall not be less than 0.3 meters.
  
  - 2) The righting lever (GZ) shall be at least 0.20 meters
  
  - 3) The area under the righting lever (GZ) curve shall not be less than  $\square 0.090$  meter-radians up to an angle of flooding  $\phi_f$ .

The angle of flooding  $\phi_f$  is the angle at which lower edge of any openings in the hull superstructures or deckhouses, being openings, which cannot be closed, watertight and which are likely to cause progressive flooding are immersed.

#### **4 Inclining test**

Every river-sea vessel shall undergo an inclining test upon its completion and the actual displacement and position of the center of gravity shall be determined for the lightriver-sea vessel condition.

Where alterations are made to a river-sea vessel affecting its lightriver-sea vessel condition and the position of the centre of gravity, the river-sea vessel shall, where the Administration considers this necessary, be re inclined and the stability information amended.

The Administration may allow the inclining test of a river-sea vessel to be dispensed with provided basic stability data is available from the inclining test of a sister river-sea vessel and it is shown to the satisfaction of the Administration that reliable stability information for that river-sea vessel can be obtained from such basic data.

#### **5 Stability information**

Approved Stability information shall be supplied to river-sea vessels to enable the master to assess with ease and certainty the stability of the river-sea vessel under various operating conditions. Such information shall include specific advice to the master warning him of those operating conditions, which could adversely affect either stability or the trim of the river-sea vessel. In particular, the information recommended in the relevant IMO Instruments referred above shall be included as appropriate. A copy of the stability information shall be submitted to the Administration or recognised organization for approval.

The approved stability information shall be kept on board, readily accessible at all times and inspected at the periodical surveys of the river-sea vessel to ensure that it has been approved.

Where alternations are made to a river-sea vessel affecting its stability, revised stability calculations shall be prepared and submitted to the recognised organisation or to the Administration for approval. Where the Administration or recognised organisation decides that the stability information must be revised, the new information shall be supplied to the master and the superseded information removed from the river-sea vessel.

## Chapter – 5 Machinery and Bilge systems

### 1 Bilge Systems

In every river-sea vessel an efficient bilge pumping arrangement shall be provided which under all practical conditions shall be capable of pumping from and draining any watertight compartment, which is neither a permanent oil tank nor a permanent water tank. In the spaces not serviced by installed piping ready access for portable pumps shall be demonstrated. Where the Administration is satisfied that the safety of the river-sea vessel is not impaired the bilge pumping arrangements may be dispensed with in any particular compartment.

The arrangement of the bilge and ballast pumping system shall be such as to prevent the possibility of water passing from the sea and from water ballast spaces into the cargo and machinery spaces, or from one compartment to another.

All distribution boxes and manually operated valves in connection with the bilge pumping arrangements shall be in positions, which are accessible under ordinary circumstances.

Every river-sea vessel shall be provided with at least two power bilge pumps.

In a river-sea vessel propelled by mechanical means fitted with single main propulsion machinery, one of the two required bilge pumps may be driven by that machinery. In every river-sea vessel fitted with twin independently operated main propulsion machinery, each such set of machinery may drive one of the required bilge pumps. In every case the propeller shaft shall be able to be readily disconnected or a controllable pitch propeller fitted.

The total capacity of the required bilge pumps shall be not less than 125 % of the total capacity of the required main fire pumps.

**Type 3** vessels, having cargo hold (s) without hatch covers, the bilge pumping capacity shall be increased by 1.5 times.

Sanitary, ballast, fire and general service pumps provided with suitable connections for bilge suction may be accepted as independent power bilge pumps.

The Administration may permit a bilge ejector in combination with an independently driven high pressure seawater pump to be installed or a portable mechanical pump to be used as substitute for one of the bilge pumps required above.

Bilge pipes shall not be led through fuel oil, ballast or double tanks, unless pipes are of heavy gauge steel construction.

## **2 Machinery Installations**

### **2.1 General machinery requirements.**

All boilers and other pressure vessels, all parts of machinery, all systems, hydraulic, pneumatic and other systems and their associated fittings which are under internal pressure shall be subjected to an approved pressure test before being put into service for the first time.

Adequate provisions shall be made to facilitate cleaning, inspection and maintenance of machinery installations including boilers and other pressure vessels.

Where risk from over speeding of machinery exists, means shall be provided to ensure that the safe speed is not exceeded.

Where main or auxiliary machinery including pressure vessels or any parts of such machinery are subject to internal pressure and may be subject to dangerous overpressure, means shall be provided where practicable to protect against such excessive pressure.

All gearing and every shaft and coupling used for transmission of power to machinery essential for the propulsion and safety of the river-sea vessel or for the safety of persons on board shall be so designed and constructed that they will withstand the maximum working stresses to which they may be subject in all service conditions, and due consideration shall be given to the type of engines by which they are driven or of which they form part.

Machinery shall be provided with, as deemed necessary by the Administration, automatic shut off arrangements or alarms in the case of failures such as lubricating oil supply failure which could lead rapidly to complete breakdown, damage or explosion. The Administration may permit provisions for overriding automatic shut off devices.

### **2.2 Controls**

Main internal combustion propulsion machinery and applicable auxiliary machinery shall be provided with automatic shut off arrangement in the case of failures such as lubricating oil supply failure which could lead rapidly to complete breakdown, serious damage or

explosion. The Administration may permit provisions for overriding automatic shut off devices.

### **2.3 Steam boilers and boilers feed systems.**

Every steam boiler and every oil-fired steam generator shall be provided with not less than two safety valves of adequate capacity. However, having regard to the output or any other features of any boiler or oil-fired steam generator, the Administration may permit only one safety valve to be fitted if it is satisfied that adequate protection against overpressure is thereby provided.

Each oil-fired boiler which is intended to operate without manual supervision shall have safety arrangements which shut off the fuel supply and give an alarm in the case of low water level, air supply failure or flame failure.

Every steam generating system which provides services essential for the safety of the river-sea vessel, or which could be rendered dangerous by the failure of its feed water supply, shall be provided with not less than two separate feed water systems from and including the feed pumps, noting that a single penetration of the steam drum is acceptable. Unless the pump is designed to prevent overpressure, means shall be provided which will prevent overpressure in any part of the systems.

Boilers shall be provided with means to supervise and control the quality of the feed water. Suitable arrangements shall be provided to preclude, as far as practicable, the entry of oil or other contaminants, which may adversely affect the boiler.

Every boiler essential for the safety of the river-sea vessel and designed to contain water at a specified level shall be provided with at least two means for indicating its water level, at least one of which shall be direct reading gauge glass.

### **2.4 Steam pipe systems**

Every steam pipe and every fitting connected thereto through which steam may pass shall be so designed, constructed and installed as to withstand the maximum working stresses to which it may be subjected.

Means shall be provided for draining every steam pipe where otherwise dangerous water hammer action might occur.

Where a steam pipe or fitting may receive steam from any source at a higher pressure than that for which it is designed a suitable pressure-reducing valve, pressure relief valve and pressure gauge shall be fitted.

## **2.5 Air pressure systems**

In every river-sea vessel means shall be provided to prevent overpressure in any part of compressed air systems and wherever water jackets or casings of air compressors and coolers might be subjected to dangerous overpressure due to leakage into them from air pressure parts. Suitable pressure relief arrangements shall be provided for all systems.

The main starting air arrangement for main propulsion internal combustion engines shall be adequately protected against the effects of backfiring and internal explosion in the starting air pipes.

All discharge pipes from starting air compressors shall lead directly to the starting air receivers, and all starting air pipes from the air receivers to main or auxiliary engines shall be entirely separate from the compressor discharge pipe system.

Provision shall be made to reduce, to the minimum, the entry of oil into the air pressure systems and to drain these systems.

## **2.6 Ventilating systems in machinery spaces**

Machinery spaces shall be adequately ventilated so as to ensure that when machinery or boiler therein are operating at full power in all weather conditions including heavy weather, an adequate supply of air is maintained to the spaces for the safety and comfort of personnel and the operation of the machinery.

In addition to complying with the requirements of above the ventilation of machinery spaces shall be sufficient under all normal conditions to prevent accumulation of oil vapour.

## **2.7 Protection against noise**

Where noise levels in machinery spaces exceeds 85 db, ear protectors shall be provided for personnel required to enter such spaces.

## **3 Requirements For Ships Propelled By Mechanical Means**

### **3.1 General**

Means shall be provided whereby normal operations of propulsion machinery can be sustained or restored even though one of the essential auxiliaries becomes inoperative. Special consideration shall be given to the malfunctioning of:

- .1 An electrical power generator, which serves as a main source of electrical power;
- .2 The sources of lubricating oil pressure;
- .3 The sources of water pressure;
- .4 An air compressor and receiver for starting or control purposes; and
- .5 The hydraulic, pneumatic or electrical means for controlling main propulsion machinery including controllable pitch propellers.

However, the Administration, having regard to overall safety considerations, may accept a partial reduction in propulsion capability during normal operations.

Special consideration shall be given to the design, construction and installation of propulsion machinery systems so that any mode of their vibrations shall not cause undue stresses in this machinery in the normal operating ranges.

### **3.2 Means of going astern**

Sufficient power for going astern shall be provided to secure proper control of the river-sea vessel in all normal circumstances.

The ability of the machinery to reverse the direction of thrust of the propeller in sufficient time and so to bring the river-sea vessel to rest within a reasonable distance from maximum ahead service speed shall be demonstrated and recorded for every new river-sea vessel as far as practicable and reasonable.

In new river-sea vessels, the stopping times, river-sea vessel headings and distances recorded on trials, together with the results of trials to determine the ability of river-sea vessels having multiple propellers to navigate and manoeuvre with one or more propellers inoperative shall be available on board for the use of the master or designated personnel.

Where the river-sea vessel is provided with supplementary means of manoeuvring or stopping, these shall be demonstrated and recorded as above.

### **3.3 Remote control of propulsion machinery**

Where remote control of propulsion machinery from the navigation bridge is provided and the machinery spaces are intended to be manned they shall comply with the following:

- .1 The speed, direction of thrust and, if applicable, the pitch of the propeller shall be fully controllable from the navigation bridge under all sailing conditions, including manoeuvring;
- .2 The remote control shall be performed, for each independent propeller, by a control device so designed and constructed that its operation does not require particular attention to the operational details of the machinery. Where multiple propellers are designed to operate simultaneously, they may be controlled by one control device;
- .3 The main propulsion machinery shall be provided with an emergency stopping device on the navigation bridge and shall be independent of the navigation bridge control system;
- .4 Propulsion machinery orders from the navigation bridge shall be indicated in the main machinery control room at the manoeuvring platform as appropriate;
- .5 Remote control of the propulsion machinery shall be possible only from one location at a time, at such locations interconnected control positions are permitted. At each location there shall be an indicator showing which location is in control of the propulsion machinery. The transfer of control between the navigation bridge and machinery spaces shall be possible only in the main machinery space or the main machinery control room. This system shall include means to prevent the propelling thrust from altering significantly when transferring control from one location to another;
- .6 It shall be possible to control the propulsion machinery locally, even in the case of failure in any part of the remote control system;
- .7 The design of the remote control system shall be such that in case of its failure an alarm will be given. Unless the Administration considers it

impracticable the present speed and direction of the thrust of the propeller shall be maintained until local control is in operation;

- .8 Indicators shall be fitted on the navigation bridge for:
  - .1 Main engine speed or propeller speed and direction of rotation, as deemed necessary by the Administration, in the case of fixed pitch propellers; or
  - .2 Propeller speed and pitch position in the case of controllable pitch propellers;
  - .3 An alarm shall be provided on the navigation bridge and in the machinery space to indicate low starting air pressure which shall be set at a level to permit further main engine starting operation. Where the remote control system of propulsion machinery is designed for automatic starting, the number of automatic consecutive attempts which fail to produce a start shall be limited in order to safeguard sufficient starting air pressure for starting locally.

In all river-sea vessels where the main propulsion and associated machinery, including main electrical supply, are provided with the various degrees of automatic or remote control and under continuous manual supervision from a control room, the arrangements and controls shall be so designed, equipped and installed that the machinery operation will be as safe and effective as if it were under direct supervision. Particular consideration shall be given to protect such spaces against fire and flooding.

#### **4 Steering gear**

Every river-sea vessel shall be provided with a main steering gear.

Subject to the provisions of paragraph above, every river-sea vessel shall be provided with an auxiliary means of steering the river-sea vessel in the event of failure of the main steering gear.

The main steering gear shall be of adequate strength and sufficient to steer the river-sea vessel at maximum ahead service speed. The main steering gear and rudderstock shall be so designed that they are not damaged at maximum astern speed.

The auxiliary means of steering shall be of adequate strength and sufficient to steer the river-sea vessel at navigable speed and capable of being brought speedily into action in an emergency.

Where power-operated main steering gear units and connections are fitted in duplicate, and each unit provides an acceptable degree of reliability and effectiveness based on the provisions of this section, no auxiliary steering gear need to be provided

The main steering power unit shall be arranged to re-start either by manual or automatic means when electrical power supply is restored after a failure.

In the event of failure of electrical power supply to main steering gear control or power unit, an alarm shall be given in the navigation bridge.

The position of the rudder, if power-operated, shall be indicated at the navigation bridge. The rudder angle indicator shall be independent of the steering gear control system.

Where a non-conventional rudder is installed, the Administration shall give special consideration to the steering system, so as to ensure that an acceptable degree of reliability and effectiveness, which is based on the provisions of this section, is provided.

## **5 Communication between navigation bridge and machinery space.**

Ships shall be provided with at least two independent means for communicating orders from the navigation bridge to the position in the machinery space or control room from which the main propulsion engines are normally controlled. One of the means shall be an engine room telegraph. The arrangement of these means shall be to the satisfaction of the Administration.

The engine room telegraph may be dispensed with if the main propulsion engine is directly controlled from the navigation bridge under normal operating conditions.

Appropriate means of communication shall be provided to any position, other than the navigation bridge, from which the engine may be controlled.

## **Engineer's alarm**

In every new river-sea vessel, an engineers' alarm shall be provided to be operated from the engine control room or at the manoeuvring platform as appropriate and clearly audible in the engineers' accommodation. The Administration may dispense with this requirement if satisfied that, due to close proximity of the engine control room or the manoeuvring platform and the engineer's accommodation, no engineers' alarm is necessary.

## **6 Additional Requirements For Ships With Periodically Unattended Machinery Spaces**

### **6.1 General**

The requirements of this part are additional to the applicable requirements of this chapter and apply to periodically unattended machinery spaces specified herein.

The arrangements provided shall be such as to ensure that the safety of the river-sea vessel in all sailing conditions, including manoeuvring, is equivalent to that of a river-sea vessel having manned machinery spaces.

Measures shall be taken to the satisfaction of the Administration to ensure that the equipment is functioning in a reliable manner and that satisfactory arrangements are made for regular inspections and routine tests to ensure continuous reliable operation.

Such river-sea vessels shall be provided with documentary evidence to the satisfaction of the Administration of their fitness to operate with periodically unattended machinery spaces.

### **6.2 Applicable requirements**

Ships having periodically unattended machinery spaces shall, as far as practicable and reasonable in the opinion of the Administration, comply with the applicable requirements of chapter II-1, part E of the 1974 SOLAS Convention for such machinery spaces.

## **Chapter 6      Electrical Installations**

### **1      General electrical requirements**

Electrical installations shall be such that:

- .1 All electrical services necessary for maintaining the river-sea vessel in normal operational and Habitable conditions will be assured without recourse to the emergency source of electrical power;
- .2 Electrical services essential for safety will be assured under emergency conditions; and
- .3 The safety of personnel and river-sea vessel from electrical hazards will be assured.

Electrical installations shall be such that uniformity in the implementation and application of the provisions of this part will be ensured.

### **2      Precaution against shock, fire and other hazards of electrical origin**

Exposed metal parts of electrical machines or equipment, which are not intended to be live, but which are liable under fault conditions to become live shall be earthed unless the machines or equipment are:

- .1 Supplied at a voltage not exceeding 50V direct current or 50V, root means square between conductors; auto-transformers shall not be used for the purpose of achieving this voltage; or
- .2 Supplied at a voltage not exceeding 250V by safety isolating transforms supplying only one consuming device; or
- .3 Constructed in accordance with the principle of double insulation.

The Administration may require additional precautions for portable electrical equipment for use in confined or exceptionally damp spaces where particular risks due to conductivity may exist.

All electrical apparatus shall be so constructed and so installed as not to cause injury when handled or touched in the normal manner.

Main and emergency switchboards shall be so arranged as to give easy access as may be needed to apparatus and equipment without danger to personnel. The switchboards shall be suitably guarded as deemed necessary by the Administration. Exposed live parts having voltages to earth exceeding a voltage to be specified by the Administration shall not be installed on the front of such switchboards. Where necessary, non-conducting mats or gratings shall be provided at the front and rear of the switchboard.

The requirement indicated above does not preclude under conditions approved by the Administration the use of:

- .1 Impressed current cathodic protective systems
- .2 Limited and locally earthed system (e.g. engine starting system)
- .3 limited and locally earthed welding systems. Where the Administration is satisfied that the equipment potential of the structure is assured in a satisfactory manner, welding systems with hull return may be installed
- .4 insulation level monitoring devices provided the circulation current does not exceed 30 mA under the most unfavorable conditions.

Where the hull return system is used, all final sub circuits, i.e. all circuits fitted after the last protective device, shall be two-wire and special precaution shall be taken to the satisfaction of the Administration.

When a distribution system, whether primary or secondary, for power, heating or lighting, with no connection to earth is used, a device capable of continuously monitoring the insulation level to earth and of giving an audible or visual indication of abnormally low insulation values shall be provided.

Except as permitted by the Administration in exceptional circumstances, all metal sheaths and armour of cables shall be electrically continuous and shall be earthed.

In every river-sea vessel other than river-sea vessels propelled by mechanical means constructed before the coming into force of this Notification for Indian river-sea vessels, cables and wiring external to equipment shall be at least of a flame retardant type and shall be so installed as not to impair their original flame retarding properties. Where necessary for particular applications, the Administration may permit the use of special types of cables such as radio frequency cables, which do not comply with the foregoing.

Cables and wiring serving essential or emergency power, lighting, internal communications or signals shall so far as practicable be routed clear of galleys, laundries, machinery spaces of category A and their casings and other high fire risk areas. Cables connecting fire pumps to the emergency switchboard shall be of fire resistant type where they pass through the high fire risk areas. Where practicable all such cables shall be run in such a manner as to preclude their being rendered unserviceable by heating of the bulkhead that may be caused by a fire in an adjacent space.

Where cables, which are installed in hazardous areas, introduce the risk of fire or explosion in the event of an electrical fault in such areas, special precaution against such risks shall be taken to the satisfaction of the Administration.

Cables and wiring shall be installed and supported in such a manner as to avoid chafing or other damage.

Terminations and joints in all conductors shall be so made as to retain the original electrical, mechanical, flame retarding and, where necessary, fire resisting properties of the cables.

Each separate circuit shall be protected against short circuit and against overload, except where the Administration may exceptionally otherwise permit.

The rating or appropriate setting of the overload protective device for each circuit shall be permanently indicated at the location of the protective device.

Lighting fittings shall be so arranged as to prevent temperature rises which could damage the cables and wiring, and to prevent surrounding material from becoming excessively hot.

All lighting and power circuits terminating in a bunker or cargo space shall be provided with a multiple pole switch outside the space for disconnecting such circuits.

Accumulator batteries shall be suitably housed, and compartments used primarily for their accommodation shall be properly constructed and efficiently ventilated.

Electrical or other equipment that may constitute a source of ignition of flammable material shall not be permitted in those compartments except as permitted in paragraph below.

No electrical equipment shall be installed in any space where flammable mixtures are liable to collect or in compartments assigned principally to accumulator batteries, in paint lockers, acetylene stores or similar spaces, unless the Administration is satisfied that such equipment is -

- .1 Essential for operational purposes
- .2 Of a type, which will not ignite the mixture concerned;
- .3 Appropriate to the space concerned; and
- .4 Appropriately certified for safe usage in the dusts, Vapour of gases likely to be encountered.

Lightning conductors shall be fitted to all masts or topmasts constructed of non-conducting materials. In river-sea vessels constructed of non-conductive materials, the lightning conductors shall be connected by suitable conductors to copper plate fixed to the river-sea vessel's hull well below the waterline.

Accumulator batteries except for batteries used in self-contained battery operated lights shall not be located in sleeping quarters. The Administration may permit relaxation from this requirement where hermetically sealed batteries are installed.

### **3 Main source of electrical power**

A main source of electrical power of sufficient capacity to supply all those services referred to in paragraph 1.1 shall be provided. This main source of electrical power shall consist of a generator driven by an internal combustion engine, which may be the main propulsion machinery of the river-sea vessel in the case of the river-sea vessel propelled by mechanical means.

A main electrical lighting system, which shall provide illumination throughout those parts of the river-sea vessel normally accessible to, and used by, crew or persons on board shall be supplied from the main source of electrical power.

The arrangement of the main electric lighting system shall be such that a fire or other casualty in spaces containing the main source of electrical power associated transforming equipment and main switchboard will not render the emergency electric lighting system inoperative.

The arrangement of the emergency electric lighting system shall be such that a fire or other casualty in spaces containing the emergency source of electrical power, associated transforming equipment and emergency switchboard will not render the main electrical lighting system required by this section inoperative.

#### 4 Emergency sources of electrical power

A self-contained emergency source of electrical power shall be provided.

The emergency source of electric power, associated transforming equipment, if any, and emergency switchboard shall be located above the uppermost continuous deck and shall be readily accessible from the open deck. They shall not be located forward of the collision bulkhead, except where permitted by the Administration in exceptional circumstances.

The location of the emergency source of electrical power, associated transforming equipment, if any, and emergency switchboard in relation to the main source of power, associated transforming equipment, if any and main switchboard shall be such as to ensure to the satisfaction of the Administration that a fire or other casualty in the space containing the main source of electrical power, associated transforming equipment, if any and main switchboard, or in any machinery space of category A will not interfere with the supply, control and distribution of the emergency source of electrical power.

Provided that suitable measures are taken for safeguarding independent emergency operation under all circumstances, the emergency generator may be used, exceptionally, and for short periods, to supply non-emergency circuits.

The electrical power available shall be sufficient to supply all those services that are essential for safety in an emergency, due regard being paid to such services as may have to be operated simultaneously. The emergency source of electrical power shall be capable, having regard to starting currents and the transitory nature of certain loads, of supplying simultaneously at least the following services for a period specified hereinafter, if they depend upon an electrical source for their operation:

- .1 for a period of three hours means for illumination.
- .2 for a period of eighteen hours, emergency lighting:
  - .1 In all service and accommodation alleys, stairways and exists;
  - .2 In spaces containing propulsion machinery used for navigation, if any, and main source of electrical power and their control positions;
  - .3 In all control stations, machinery control rooms, and at each main and emergency switchboard;
  - .4 At all stowage positions for fireman's outfits;

- .5 at the steering gear, if any; and
- .6 At the emergency fire pump and its control position.
- .3 For a period of eighteen hours:
  - .1 the navigation lights and other lights required by the 1972 Collision Regulations;
- And
- .2 The VHF, MF and MF/HF radio installations required by chapter 5 of the Notification for Indian river-sea vessels or chapter IV of the 1974 SOLAS Convention; and
- .4 For a period of eighteen hours:
  - .1 all internal communication equipment as required in an emergency;
  - .2 The fire detection and fire alarm systems; and
  - .3 Operations of emergency fire pumps, if electrically operated.

The requirements of period of operation of systems described in 4.2, 4.3 and 4.4 shall be reduced to six hours for Type III river-sea vessels.

The emergency source of electrical power may be either:

- .1 An accumulator battery capable of carrying the emergency electrical load line without recharging or excessive voltage drop; or
- .2 A generator driven by a suitable prime mover with an independent fuel supply and starting to the satisfaction of the Administration.

Where the emergency source of power is an accumulator battery, it shall be automatically connected to the emergency switchboard upon failure of the main source of electrical power. Where automatic connection to the emergency switchboard is not practical, manual connection may be acceptable to the satisfaction of the Administration.

Where the emergency source of power is a generator, it shall be automatically started and connected to the emergency switchboard within 45 s of the loss of the main source of electrical power. It shall be driven by a prime mover with an independent fuel supply having a flashpoint not less than 43°C. Automatic starting of the emergency generator will not be required where a transitional source of power to the satisfaction of the Administration is provided.

## Chapter 7      Structural Fire Protection

### 1.1      Constructional fire safety measures

1.1.1 The hull, superstructure, structural bulkheads, decks and deckhouses of river-sea vessel under this Notifications shall be constructed of steel or other equivalent material. Material other than steel, in case used shall be insulated to the same fire retardant properties as steel. In case alternate arrangements are proposed, the same shall be submitted to the Administration for approval, along with details and calculation substantiating the equivalence of the material used.

1.1.2 For river-sea vessel under this Notifications less than 1600 GT, the bulkheads and decks separating the engine room from the accommodation spaces and the wheelhouse and accommodation spaces shall be constructed of steel suitably insulated by fire retardant covering as per IRS / IS standards.

1.1.3 For river-sea vessel under this Notifications of 1600 GT and above, the bulkheads and decks separating the machinery spaces from control stations, corridors, accommodation spaces, stairways, service spaces and cargo spaces shall be so constructed as to be capable of preventing the spread of fire to the unexposed side. A general guidance as indicated in the table below shall be followed between adjacent bulkheads and decks:

	1	2	3	4	5
Control Stations (1)	A0	A60	A60	A60	A0
Accommodation spaces (2)		C	A0	A60	A0
Service Spaces (3)			A0	A60	*
Machinery Spaces (4)				*	A0
Other Spaces (5)					*

Where and \* appears in the tables the division requires to be steel or other equivalent material but is not required to be of "A" class standard.

Interior stairways below the weather deck shall be of steel or other material having acceptable fire resisting properties.

## **1.2 Insulation materials**

1.2.1 Insulation materials in accommodation spaces, service spaces (except domestic refrigeration compartments), control stations and machinery spaces shall be non-combustible. Vapour barriers and adhesive used in conjunction with insulation, as well as insulation of pipes fittings, for cold service systems, need not be non-combustible materials, but they shall be kept to the minimum quantity practicable and their exposed surfaces shall have qualities of resistance to the propagation of flame to the satisfaction of Administration.

## **1.3 Restricted use of combustible material**

1.3.1 All exposed surfaces in corridors and stairway enclosures and surfaces including decks in concealed or inaccessible spaces in accommodation spaces, service spaces and control stations shall have low flame-spread characteristics. Exposed surfaces of ceilings in accommodation spaces, service spaces and control stations shall have low flame-spread characteristics.

1.3.2 Paints, varnishes and other finishes used on exposed interior surfaces shall not offer an undue fire hazard in the judgment of the Administration and shall not be capable of producing excessive quantities of smoke.

## **1.4 Means of escape**

1.4.1 Stairways and ladders shall be so arranged as to provide, from accommodation spaces, service spaces, control stations, machinery spaces and other spaces in which the crew is normally employed, ready means of escape to the open deck and thence to the survival craft.

1.4.2 Two means of escape shall be provided from every machinery space that shall be as widely separated as possible. Vertical escapes shall be by means of steel ladders or other means acceptable to the Administration as suitable alternatives. Where the size of such machinery space makes it impracticable, one of these means of escape may be dispensed with provided that the means provided is to the satisfaction of the Administration.

## **1.5 Special arrangements in machinery spaces**

1.5.1 The following provisions shall apply to machinery spaces.

1. Means shall be provided for opening and closure of skylights, opening and closure of windows in machinery space boundaries, closure of openings in funnels, which normally allow exhaust ventilation, and closure of ventilator dampers.
2. Means shall be provided for permitting the release of smoke.
3. The means required in 1 and 2 shall be located outside the space concerned where they will not be cut off in the event of fire in the space they serve.
4. Windows shall not be fitted in machinery space boundaries. This does not preclude the use of glass in control rooms within the machinery space.
5. Doors fitted in machinery space boundaries shall as far as practicable be equivalent in resisting fire to the divisions forming such boundaries. Where such doors are not weather tight or watertight doors, they shall be self-closing.

## **1.6 Ventilation systems**

- 1.6.1 Ventilation systems of each of the following groups of spaces shall be entirely separated from each other:
  1. machinery spaces;
  2. galleys;
  3. cargo spaces; and
  4. accommodation spaces and control stations.
- 1.6.2 The arrangement of each ventilation system shall be such that fire in one space shall not readily spread to the other spaces.
- 1.6.3 The main inlets and outlets of all ventilation systems shall be capable of being closed from outside the spaces being ventilated.

## **1.7 Ventilation of tanks, cofferdams, etc.**

- 1.7.1 All tanks carrying cargo, cofferdams and other enclosed spaces in all river-sea vessels shall be provided with effective means for ventilation and access to the satisfaction of the Administration, having regard to the intended services.

## **1.8 Miscellaneous items**

- 1.8.1 Where bulkheads, decks, ceiling or linings are penetrated for the passage of electric cables, pipes, trunk, etc., or for the fitting of ventilation terminals, lighting fixtures and similar devices, or for girders, beams or other structural members, arrangements shall be made to ensure that the fire integrity is not impaired.
- 1.8.2 Where the Administration may permit the conveying of oil and combustible liquid through accommodation and service spaces, the pipes conveying oil or combustible liquids shall –
1. be of a material approved by the Administration, having regard to the fire risk;
  2. not be concealed; and
  3. carry only low-pressure liquids and not normally be used at sea.
- 1.8.3 Materials readily rendered ineffective by heat shall not be used for overboard scuppers, sanitary discharges and other outlets which are close to the waterline and where the failure of the material in the event of fire would give rise to danger of flooding.

## **1.9 Arrangement for oil fuel, lubricating oil and other flammable oils Limitations in the use of oil as fuel**

- 1.9.1 The following limitations shall apply to the use of oil as fuel:
1. Except as otherwise permitted by this paragraph; no oil fuel with a flashpoint of less than 60°C shall be used.
  2. For ~~in~~ diesel engines in emergency applications oil fuel with a flashpoint of not less than 43°C is permitted to be used, provided the oil storage tank is outside the main machinery space and subject to such additional precautions as it may consider necessary and on condition that the ambient temperature of the space in which such oil fuel is stored or used shall not be allowed to rise to within 10°C below the flashpoint of the oil fuel. In emergency generators oil fuel with a flashpoint of not less than 43°C shall be used.

## **1.10 Oil fuel arrangements**

- 1.10.1 In a river-sea vessel in which oil fuel is used, the arrangements for the storage distribution and utilization of the oil fuel shall be such as to ensure the safety of the river-sea vessel and persons on board and shall at least comply with the following provisions:

1. As far as practicable, parts of the oil fuel systems containing heated oil under pressure exceeding 0.18 N/mm<sup>2</sup> shall not be placed in a concealed position such that defects and leakage cannot readily be observed. The machinery spaces in way of such parts of the oil fuel systems shall be adequately illuminated.
2. As far as practicable, oil fuel tanks shall be part of the river-sea vessel's structure and shall be located outside machinery spaces of category A. Where oil fuel tanks, other than double bottom tanks, are necessarily located adjacent to, or with in, machinery spaces of category A, at least one of their vertical sides shall be contiguous to the machinery space boundaries, and shall preferably have a common boundary with the double bottom tanks, where fitted, and the area of the tank boundary common with the machinery spaces shall be kept to the minimum. Where such tanks are situated within the boundaries of machinery spaces of category A, they shall not contain oil fuel having a flashpoint of less than 60°C. In general, the use of freestanding oil fuel tanks shall be avoided. Where permitted, they shall be provided with an oil tight spill tray of suitable size having a drainpipe leading to a safe place to the satisfaction of the Administration.
3. Oil fuel storage, settling or daily service tanks situated above the double bottom shall be fitted with a cock or valve constructed of similar material to that of the tank, directly on the tank capable of being closed from a safe position outside the space concerned in the event of a fire occurring in the space in which such tanks are situated. Such tanks of not more than 250 L capacity need not comply with this paragraph.
4. Safe and efficient means of ascertaining the amount of oil fuel contained in any oil fuel tank shall be provided. Sounding pipes shall not terminate in any space where the risk of ignition of spillage from the sounding pipe might arise. In particular, they shall not terminate in accommodation spaces. Other means of ascertaining the amount of oil contained in any oil fuel tank shall be provided. Sounding pipes shall not terminate in any space where the risk of ignition of spillage from the sounding pipe might arise. In particular, they shall not terminate in accommodation spaces. Other means of ascertaining the amount of oil fuel contained in any fuel tank may be permitted, provided that the failure of such means or overfilling of the tanks will not permit release of fuel. The Administration may permit the use of oil level gauges with flat glasses and self-closing valves between the gauge glasses and the oil tanks. Cylindrical gauge glasses may also be permitted in freestanding oil fuel tanks provided that they are suitably protected and fitted with self-closing valves to the satisfaction of the Administration.

5. Provisions shall be made to prevent overpressure in any oil tank or in any part of the oil fuel system including the filling pipes. Relief valves and air or overflow pipes shall discharge to a position, which in the opinion of the Administration is safe. The open ends of air pipes shall be fitted with wire mesh.
6. The ventilation of machinery spaces shall be sufficient under all normal conditions to prevent accumulation of oil vapour.

### **1.11 Lubricating oil arrangements**

- 1.11.1 The arrangements for storage, distribution and utilisation of oil used in pressure lubricating systems shall be such as to ensure the safety of the river-sea vessel and persons on board, and such arrangements in machinery spaces shall at least comply with the provisions of 4.10.1.1, .3, .4 and .5 except that this does not preclude the use of sight flow glasses in lubricating systems.

### **1.12 Arrangements for other flammable oils**

- 1.12.1 The arrangements for storage, distribution and utilization of other flammable oils employed under pressure in power transmission systems, control and activation systems and heating systems shall be such as to ensure the safety of the river-sea vessel and persons on board. In locations where means of ignition are present, such arrangements shall at least comply with the provisions of 4.10.1.1
- 1.12.2 No oil fuel tank or lubricating oil tank or any other flammable oil tank shall be situated where spillage or leakage there from can constitute a hazard by falling on heating surfaces. Precautions shall be taken to prevent any oil that may escape under pressure or oil leakage from any pump, filter, piping system or heat exchanger from coming into contact with heated surfaces or enter into machinery air intakes. Where necessary, a suitable spill tray or gutter screen or other suitable arrangement shall be provided to allow oil to drain to a safe place in the event of spillage or leakage of oil from such an oil tank, machinery, equipment or system. The number of joints in piping systems shall be kept to a minimum practicable.
- 1.12.3 Pipes, fittings and valves handling fuel oil, lubricating oil and other flammable oils shall be of the steel or other approved material, except that restricted use of flexible pipes shall be permissible in positions where the Administration is satisfied that they are necessary. Such flexible pipes and end attachments shall

be of approved fire-resisting materials of adequate strength and shall be constructed to the satisfaction of the Administration.

1.12.4 Oil fuel, lubricating oil or other liquid substances flammable or harmful to the marine environment shall not be carried in forepeak tanks.

1.12.5 Any oil or other substances flammable or harmful to the marine environment shall not be carried in other tanks or spaces, which are not specially approved by the Administration for such purposes.

### **1.13 Carriage of oxygen and acetylene cylinders**

1.13.1 Carriage of oxygen and acetylene cylinders of use on board while sailing shall not be permitted unless an approved "work permit" system is in place.

### **1.14 Cooking areas**

1.14.1 In case of a small cooking area that is common with the accommodation, the structural fire protection shall be suitably made hazard proof by employing electric hot plate of maximum 3 kW capacity. The use of deep fat fryers, tandoors, barbeques shall not be permitted.